



## A Series Pallet Stacker Mini Range (Single column)

with capacities of 1,000 to 1,200kg

### High Performance

- / Strong power to satisfy most applications of material handling.
- / Latest permanent magnetic system including motor and controller applied to provide excellent, efficient performance.
- / Regenerative brake and slope anti-slide function are offered by this truck.

### Reliability

- / CDD: The adopted four-pivot design to provide reasonable driving wheel balance and good visibility and reliability.
- / The applied lifting system with optimized design is more stable and reliable.
- / Water-proof plugs and connectors applied to provide a reliable protection to electric system.
- / Top quality hydraulic power unit applied to provide low noise, low vibration, smooth lifting and landing.
- / Punch-formed forks to provide more strength and tip guide to provide higher efficient operation.

### Standard Specification

- / Horn
- / PU drive wheel
- / Internal charger
- / Multi-function tiller
- / Tandem load wheels
- / 1150mm fork length
- / Hydraulic power unit
- / Maintenance free battery
- / 560mm outside fork width
- / Permanent magnetic motor
- / Emergency disconnect switch
- / CURTIS permanent magnetic controller
- / 1.5m standard mast

### Options

- / Load backrest
- / 1220mm fork length
- / 680mm outside fork width
- / Cold store protection(-30 C)
- / 2m mast

### Comfort

- / Simple and beautiful tiller designed to operate all functions easily even by one hand.
- / Optimized design to offer a good visibility and easy entrance of the pallet.
- / Built-in charger and maintenance free gel battery adopted to provide convenient usage.
- / Compact size to offer smart operations and pass of narrow aisle.

### Safety

- / With three braking types: releasing brake, reversing brake and emergency brake, the driving safety has been ensured.
- / The applied slope anti-slip function ensures the safety of the operation.
- / The emergency button on the tiller head can effectively avoid the harm to the driver in emergent situations when driving in reverse.
- / The standard equipped electronic lifting limitation and soft landing system protect working motor and loads from damaging.



# 1.0/1.2t Mini Range Pallet Stacker Single Column Specification:

Mast Type	Max Lifting Height h <sub>3</sub>	Max. fork height (h <sub>3</sub> +h <sub>13</sub> )	Lowered Height h <sub>1</sub>	Extended Height h <sub>4</sub>	Free lift	Load Capacity at 600mm/23.6in	
						1.0t/2205lb	1.2t/2646lb
Single cylinder Single mast	mm/in	mm/in	mm/in	mm/in	mm/in	Kg/lb	Kg/lb
	1500/59.1	1585/62.4	1979/77.9	1986/78.2	1493/58.8	1000/2205	1200/2646
	1750/68.9	1835/72.2	2229/87.7	2236/87.8	1743/68.6	1000/2205	1200/2646
	2000/78.7	2085/82.1	2479/97.6	2486/97.9	1993/78.5	1000/2205	1200/2646

## A Series Pallet Stacker Mini Range-Single Column

		HANGCHA GROUP CO.,LTD.						
Distinguishing mark	1.1	Manufacturer						
	1.2	Manufacturer's type designation	CDD10-AMC1	CDD12-AMC1	CTD10-AMC1	CTD12-AMC1		
	1.4	Operator type: hand, pedestrian, standing, seated, order-picker	Pedestrian		Pedestrian		Pedestrian	
	1.5	Rated capacity/rated load	Q (kg/lb)	1000/2205	1200/2646	1000/2205	1200/2646	
	1.6	Load centre distance	c (mm/in)	600/23.6	600/23.6	600/23.6	600/23.6	
1.9	Wheelbase	y (mm/in)	1197.5/47.1	1197.5/47.1	1197.5/47.1	1197.5/47.1		
Weight	2.1	Service Weight	kg/lb	500/1102	500/1102	500/1102	500/1102	
Tyres, chassis	3.1	Tyres: solid rubber, superelastic, pneumatic, polyurethane	PU		PU		PU	
	3.2	Tyre size, front	mm/in	φ250/9.8x80/3.1	φ250/9.8x80/3.1	φ250/9.8x80/3.1	φ250/9.8x80/3.1	
	3.3	Tyre size, rear	mm/in	φ85/3.3x70/2.8	φ85/3.3x70/2.8	φ85/3.3x70/2.8	φ85/3.3x70/2.8	
	3.4	Additional wheel (dimensions)	mm/in	φ125/4.9x50/2	φ125/4.9x50/2	φ125/4.9x50/2	φ125/4.9x50/2	
	3.5	Wheels, number front / rear (x = driven wheels)		1x+1/4	1x+1/4	1x+1/4	1x+1/4	
	3.6	Tread, front	b <sub>10</sub> (mm/in)	520/20.5	520/20.5	520/20.5	520/20.5	
	3.7	Tread, rear	b <sub>11</sub> (mm/in)	390/15.4	390/15.4	390/15.4	390/15.4	
Dimensions	4.4	Lift	h <sub>3</sub> (mm/in)	1500/59.1	1500/59.1	1500/59.1	1500/59.1	
	4.15	Fork height, lowered	h <sub>13</sub> (mm/in)	90/3.5	90/3.5	90/3.5	90/3.5	
	4.19	Overall length	l <sub>1</sub> (mm/in)	1695/66.7	1695/66.7	1695/66.7	1695/66.7	
	4.21	Overall width	b <sub>1</sub> (mm/in)	800/31.5	800/31.5	800/31.5	800/31.5	
	4.22	Fork dimensions ISO 2331	s/e/l (mm/in)	60/170/1150 (2.4/6.7/45.3)	60/170/1150 (2.4/6.7/45.3)	35/100/1070 (1.4/6.742.1)	35/100/1070 (1.4/6.742.1)	
	4.25	Distance between fork-arms	b <sub>s</sub> (mm/in)	560/22.0	560/22.0	210-790/8.3-31.1	210-790/8.3-31.1	
	4.32	Ground clearance, centre of wheelbase	m <sub>2</sub> (mm/in)	35/1.4	35/1.4	35/1.4	35/1.4	
	4.34.1	Aisle width for pallets 1000 x 1200 crossways	A <sub>st</sub> (mm/in)	2002/78.8	2002/78.8	2002/78.8	2002/78.8	
	4.34.2	Aisle width for pallets 800 x 1200 lengthways	A <sub>st</sub> (mm/in)	2052/80.8	2052/80.8	2052/80.8	2052/80.8	
	4.35	Turning radius	W <sub>a</sub> (mm/in)	1422/56.0	1422/56.0	1422/56.0	1422/56.0	
Performance data	5.1	Travel speed, laden/unladen	km/h mph	4.2/4.5 2.6/2.8	4.2/4.5 2.6/2.8	4.2/4.5 2.6/2.8	4.2/4.5 2.6/2.8	
	5.2	Lift speed, laden/unladen	m/s (ft/min)	0.140/0.230 (27.6/45.3)	0.120/0.230 (23.6/45.3)	0.140/0.230 (27.6/45.3)	0.120/0.230 (23.6/45.3)	
	5.3	Lowering speed, laden/unladen	m/s (ft/min)	0.180/0.170 (35.4/33.5)	0.180/0.170 (35.4/33.5)	0.180/0.170 (35.4/33.5)	0.180/0.170 (35.4/33.5)	
Electric engine	5.8	Max Gradeability, laden/unladen	%	6/10	6/10	6/10	6/10	
	6.1	Drive motor rating S2 60 min	kW/hp	0.7/0.94	0.7/0.94	0.7/0.94	0.7/0.94	
	6.2	Lift motor rating at S3 15%	kW/hp	2.2/2.95	2.2/2.95	2.2/2.95	2.2/2.95	
	6.4	Battery voltage, rated capacity	V/Ah	2x12/70	2x12/70	2x12/70	2x12/70	
	8.1	Type of drive control		DC	DC	DC	DC	
9.1	Manufacturer		Curtis	Curtis	Curtis	Curtis		

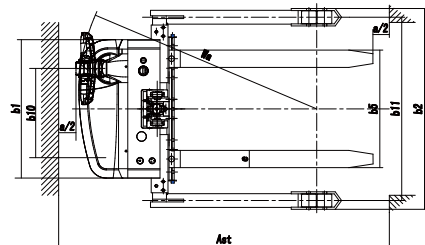
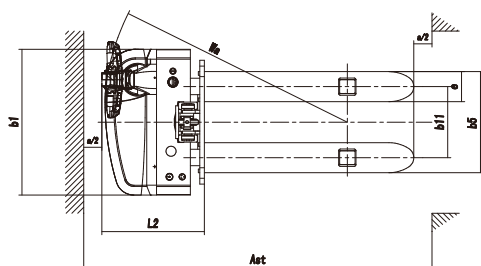
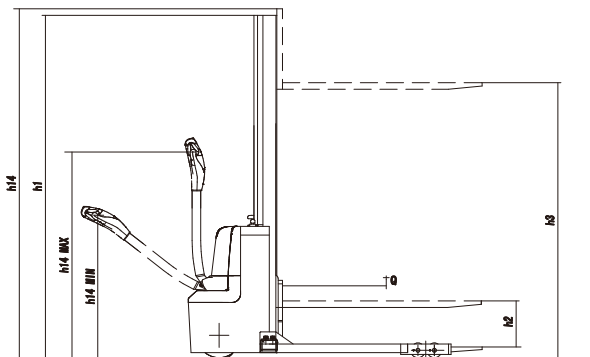
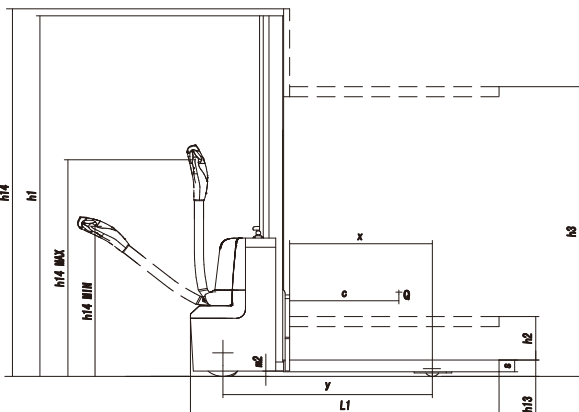



**HANGCHA FORKLIFT CANADA INC.**

**Company address:**

6-980 Rue Valois, Vaudreuil-Dorion,  
QC, J7V 8P2, Canada

Toll Free: 877-319-HCFC (4232)

Landline: 450-319-HCFC

[info@hcforkliftcanada.com](mailto:info@hcforkliftcanada.com)  
[www.hcforkliftcanada.com](http://www.hcforkliftcanada.com)



ISO14001:2015



ISO9001:2015



Follow us on  
Facebook



Follow us on  
YouTube



Follow us on  
WeChat



Download "Hangcha  
Forklift" App



HANGCHA GROUP CO., LTD. reserves the right to make any changes without notice concerning colors, equipment, or specifications detailed in this brochure, or to discontinue individual models. The colors of trucks, delivered may differ slightly from those in brochures.