

LI-ION
TECHNOLOGY

INNOVATIVE LITHIUM-ION



A Series Tiller Tractor

with capacities of 10,000lbs

The World of Hangcha
SINCE 1956



LET THE LITHIUM POWER UNLEASH



HANGCHA PROVIDES **5 YEAR**
OR 1000 HOURS GUARANTEE
ON LITHIUM BATTERY.



5 YEAR
WARRANTY

INNOVATIVE SOLUTIONS NEW POWER NOW

Innovative, reliable lithium-ion technology (Lithium Iron-Phosphate), which are developed jointly by HANGCHA and CATL. Battery cells and modules are from CATL, with reliable quality, exclusively for HANGCHA.

- / We use square lithium iron phosphate batteries and modules used in large quantities by commercial vehicles in mature economies.
- / The module uses an aluminum alloy frame which is sturdy, lightweight and with excellent heat dissipation.
- / Safe and effective: Charging efficiency as high as 98%, thermal runaway temperature 600 °C or above.
- / Adapted to low temperatures: Comes standard with an electrical heating feature, ensuring normal operation in low temperatures.
- / Quick charging.
- / Long-working: 4000 charging cycles, capacity retention greater than 80%.
- / Maintenance-free: Battery does not require manual maintenance.
- / Green and clean: Pollution-free, zero emissions.

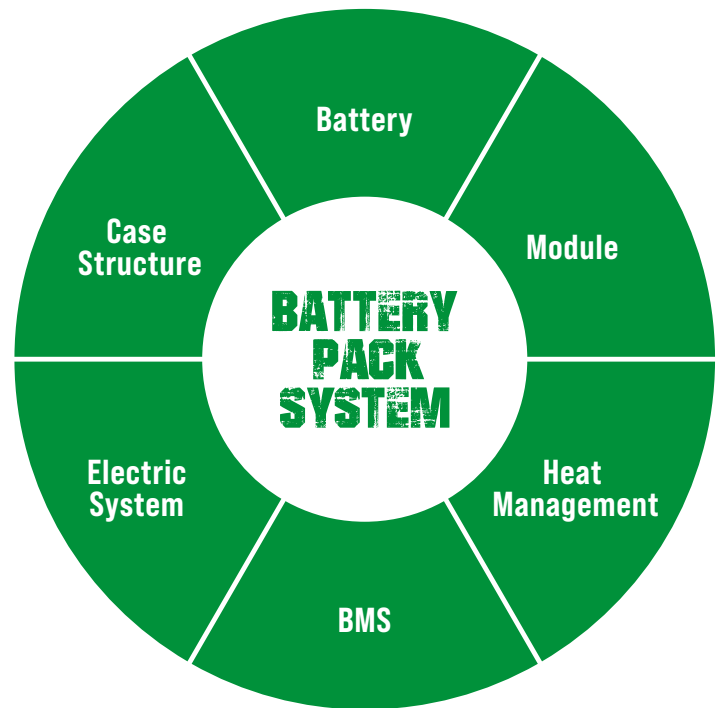

Rapid charging and opportunity charging ensure continuous availability of vehicles

Allow for fast full charging or boost charging. They are maintenance free and do not require a battery change when used for multi-shift operations.



A NEW DIMENSION OF PERFORMANCE

A series Tiller Tractor is a kind of material handling equipment developed by HANGCHA for North American market under high intensity working condition. It adopts AC driving control technology, advanced performance, comfortable operation, safe and reliable, low maintenance cost, the utility model is an ideal tool for short-distance material pulling operation in the workshop or warehouse of an enterprise.



Appearance

- / A series Tiller Tractor adopts a professional exterior industrial design. The truck has a smooth vivid profile and a fully ergonomic design, following the latest exterior design trend.
- / With a large number of steel plate stamping and injection molding processes to enable a robust and durable product that meets environmental protection requirements.

High Performance

- / EPS(Electric Power Steering) system help operators working more comfortable.
- / The maintenance-free high-power brushless AC traction motor has excellent acceleration performance, good climbing performance and low heat generation.
- / The CURTIS control system provides accurate, stable and more efficient control.
- / The CANBUS structure makes the communication of the truck faster and more reliable.
- / The truck has a regenerative braking function and provides protection to prevent sliding down a ramp.
- / The switches, connectors and other key parts are all products of internationally renowned brands.

Comfort

- / Middle operation mode, large driving space, double pedal cushion and Ergonomic backrest make driving more comfortable.
- / With the compact and stylish tiller, all operations can be completed with one hand.
- / With the turtle speed, the truck can be more easily and accurately driven slowly.

Reliability

- / With a high-strength steel frame structure, the truck frame has a large residual load capacity and a long service life.
- / As a standard, the auxiliary wheels can improve the stability of the turn.
- / The electrical system uses waterproof connectors, and all wires and cables have reliable protection, which greatly improves the reliability.
- / The lithium-ion vehicle is equipped with special li-ion batteries developed for off-road vehicles. The batteries are made of Ningde era batteries, which have high energy density, fast charging speed and long service life.



Batters side roll out



The dashboard with integrated large-screen instruments can be moved sideways to enable the changing battery easier



Different traction hook assemblies can be selected as required



The standard point switch at the backrest greatly improves the convenience of operation



45

LI-ION BATTERY
HANGCHA



曼尼通红
6S-773
3S-775
名称 数量
型号 AMB200-400001-000
数量 4 只
地址: 余姚市阳明路119-3号 电话: 0574-62113200 手机: 13777159488
网址: www.hangcha.com.cn 电子邮箱: online@hangcha.com

曼尼通红
6S-773
3S-775
名称 数量
型号 AMB200-400001-090
数量 4 只
地址: 余姚市阳明路119-3号 电话: 0574-62113200 手机: 13777159488
网址: www.hangcha.com.cn 电子邮箱: online@hangcha.com

Safety

- / With the functions of release braking, and emergency braking to ensure safe driving.
- / With protection to prevent sliding down a ramp to ensure safe operations.
- / The red brake button on the head of the tiller can be pressed to effectively brake and prevent the driver from being injured.
- / When the "rabbit" switch is turned on, the driver automatically reduces the maximum steering angle to avoid the danger of sudden large-angle turns at high speed.
- / When the driver releases the pedal to drive, the acceleration button is invalid, in order to protect the driver's safety.

Standard Specification

- / AC drive motor
- / AC Curtis controller
- / Ring traction hook
- / Multi-functional large-screen instrument
- / EPS(Electric Power Steering) system
- / Key switch
- / Training wheel
- / PU drive wheel
- / Rubber load wheel
- / Battery side roll-out
- / Horn

Maintenance

- / With a maintenance-free brushless AC drive motor to significantly reduce the operating costs.
- / The multi-functional large-screen instruments integrate battery display and real-time speed and fault self-diagnosis functions to facilitate maintenance.
- / With a rear hood that can be completely opened to expose all components and facilitate the maintenance.
- / With all spindles equipped with lubricated sleeves and oil cups to facilitate maintenance and a long service life.

Options

- / A full range of batteries capacity (300-750Ah)
- / Different forms of traction hook
- / Adjustable height handle
- / Tool box
- / Blue spot
- / Fan



A Series Tiller Tractor Specification

			HANGCHA GROUP CO.,LTD.	
Distinguishing mark	1.1	Manufacturer		
	1.2	Manufacturer's type designation	QDD45-ASC1-NAI	QDD45-ASC1-NA
	1.3	Drive: electric (battery or mains), diesel, petrol, fuel gas	Electric	Electric
	1.4	Operator type	Rider	Rider
	1.5	Rated capacity/rated load	Q(kg/lb)	4500/10000
	1.7	Rated drawbar pull	F(N)	1078/250
	1.9	Wheelbase	y(mm/in)	960/37.8
Weight	2.1	Service weight(Including battery)	kg/lb	1130/2490
Tyres, chassis	3.2	Tyre size, front	$\Phi 310 \times 110$	$\Phi 310 \times 110$
	3.3	Tyre size, rear	$\Phi 200 \times 100$	$\Phi 200 \times 100$
	3.5	Wheels, number front/rear	1 \times +2/2	1 \times +2/2
	3.6	Tread, front	b ₀ (mm/in)	600/23.6
	3.7	Tread, rear	b ₁ (mm/in)	754/29.7
Dimensions	4.19	Overall length	l(mm/in)	1567/61.7
	4.21	Overall width	b(mm/in)	860/33.9
	4.32	Ground clearance, centre of wheelbase	m ₂ (mm/in)	80/3.15
	4.35	Turning radius	W _a (mm/in)	1193/47
Performance data	5.1	Travel speed, laden/unladen	kph(mph)	9/14(5.6/8.7)
	5.5	Drawbar pull	N/lbf	1078/250
	5.6	Max drawbar pull	N/lbf	3332/750
	5.7	Gradeability(laden)	%	5
	5.10	Service break		Electromagnetic
Electric-engine	6.1	Drive motor rating S2 60 min	kW/hp	4/5.4
	6.4	Battery voltage, nominal capacity K5	V/Ah	24/404
	8.1	Type of drive control		AC
	9.1	Manufacturer		Curtis

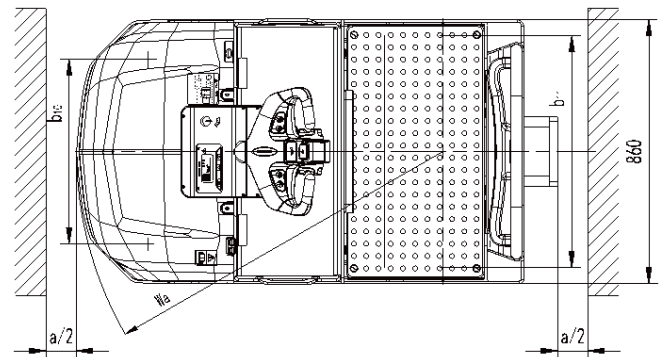
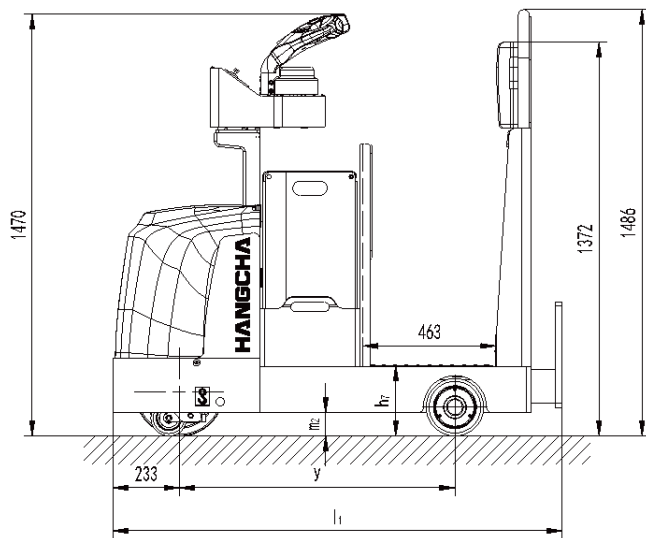





HANGCHA FORKLIFT CANADA INC.

Company address:

6-980 Rue Valois, Vaudreuil-Dorion,
QC, J7V 8P2, Canada

Toll Free: 877-319-HCFC (4232)

Landline: 450-319-HCFC

info@hcforkliftcanada.com

www.hcforkliftcanada.com



ISO14001:2015



ISO9001:2015



Follow us on
Facebook



Follow us on
YouTube



Follow us on
WeChat



Download "Hangcha
Forklift" App

HANGCHA GROUP CO., LTD. reserves the right to make any changes without notice concerning colors, equipment, or specifications detailed in this brochure, or to discontinue individual models. The colors of trucks, delivered may differ slightly from those in brochures.