

A Series Lithium-ion Light Duty Walkie Pallet Jack

with a load capacity of 4,000lbs

LI-ION
TECHNOLOGY

INNOVATIVE LITHIUM-ION



The World of Hangcha
SINCE 1956



HANGCHA

CANADA



A20

HANGCHA



A Series Lithium-ion Light Duty Walkie Pallet Jack

The A Series Lithium-ion Light Duty Pallet Jack is a new generation product recently developed by Hangcha Group for warehousing and logistics applications. By combining lithium-ion technology and permanent magnet drive technology, the truck is now more reliable, safer, and has a lower operational cost. Its advanced performance is perfect for loading, unloading and handling palletized goods in warehouses, supermarkets, workshops, and homes.



Appearance and Ergonomics



Appearance:

- The A Series Lithium-ion Light Duty Walkie Pallet Jack has a smooth vivid profile and was designed to be ergonomic. The exterior of this forklift is powder coated in a durable, easy to see, green finish.
- This pallet truck uses stamped steel plates and injection molded parts. This creates a robust and durable product that is able to successfully take on the wear and tear of a warehouse environment.

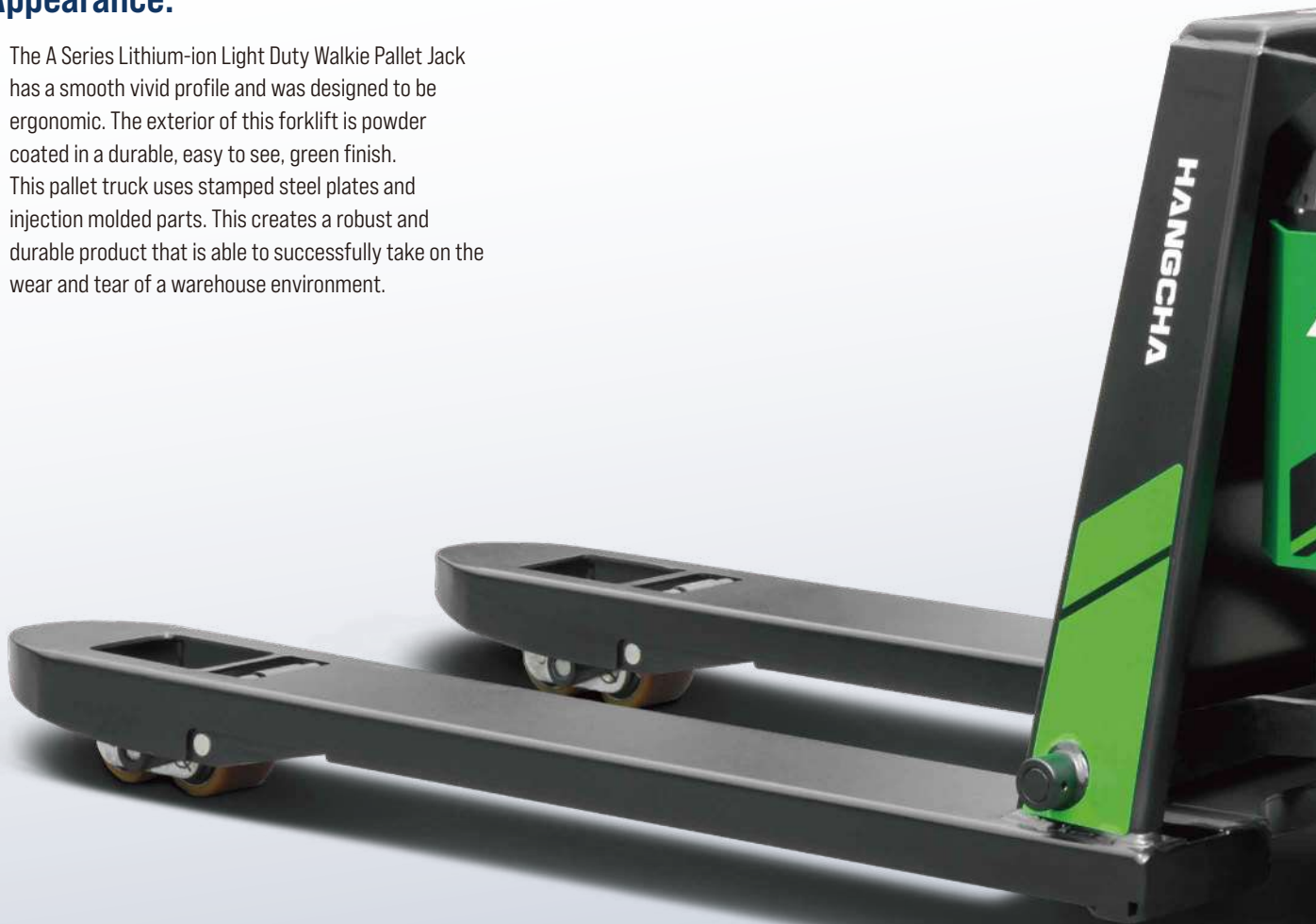



High Performance:

- The walkie pallet jack is designed to meet customer's needs thanks to its high power and 4,000lb load capacity.
- The DC permanent magnet and permanent magnet synchronous traction motor provide excellent performance and low heat generation.
- The truck's regenerative braking function also prevents it from sliding down a ramp.



High Power



High-end Cell



Code Lock

Comfort:

- The newly-developed control head is reliable, stylish, and compact. All of the operational inputs can be completed with one hand.
- The code lock prevents unauthorized personnel from using the equipment.
- The pallet jack is easy to steer thanks to its low steering resistance.
- With a high-end cell and multiple safety protection systems, the high-performance lithium battery has a long service life, maintenance-free, safe, reliable, and can be charged quickly and replaced easily.
- Thanks to the compact, lightweight, and flexible design, the pallet jack is easy to operate. The pallet jack is also designed to operate efficiently in narrow aisles environments like a container thanks to its upright walking function.
- With only a 3.15" fork clearance, it is designed to fit a variety of pallets.

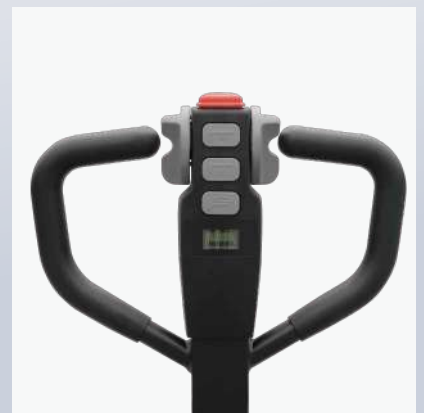



A20

HANGCHA

There Are Many Sides To Reliability



Reliability:

- The innovative structural design prevents the harness and electrical parts from moving together with the lifting parts of the pallet jack. This increases the reliability of the pallet truck substantially.
- When not in use for a certain period of time, the truck will hibernate automatically to protect the battery and prolong the pallet jacks' operational time.
- All wires and cables use waterproof plugs and connectors to increase reliability and protect the electronic components in the pallet jack.
- The low-noise, low-vibration, and high-performance hydraulic power unit enables stable and reliable lifting and lowering of goods.
- The electronic lifting limit switch is used to avoid overflow from the hydraulic power unit. This saves energy and protects the motor. The switch is highly reliable and has a long service life.
- The interlock switch is a non-contact proximity switch with high reliability.



Saves Energy



Automatically Hibernates



Waterproof



Safer and Easier to Use Everything Works Better

Safety:

- The pallet jack includes release braking, reverse braking, and emergency braking to ensure safe driving.
- The pallet jack also features an anti-rollback function to ensure safe operation.
- The emergency reverse button on the handle can effectively prevent the driver from being injured if the pallet jack moves forward in an emergency situation.
- The electronic lifting limit and mechanical limit switches prevent an impact caused by lifting goods to the top of the lifting range. This protects both the motor and the goods from being damaged.



Maintenance:

- The lithium battery can be charged quickly and replaced easily.
- The novelty-designed handle has key switches that can be replaced separately.
- The power display allows users to see when the battery needs to be charged.
- The maintenance hatch hood opens very easily to expose all components and facilitate easy maintenance of the pallet jack.
- All of the spindles are equipped with self-lubricated sleeves and oil cups to promote a long service life.



The A Series Lithium-ion Light Duty Walkie Pallet Jack comes standard with an external charger.





Standard Specification

- Permanent Magnet Synchronous Traction Motor
- Single Load Wheels
- 27" Fork Width
- 45" Fork Length
- Pin Code Lock
- Emergency Cut Off Switch
- Multi-Function Meter
- High-Performance Lithium Battery
- Non-Contact Interlock Switch
- Electronic Lifting Limit Switch
- Upright Walking
- Horn
- External Charger

Options

- 22" Fork Width
- 48" Fork Length
- Tandem Load Wheel
- Key Switch



A Series Lithium-ion Light Duty Walkie Pallet Jack Specification

Distinguishing Marks	1.1	Manufacturer		HANGCHA GROUP CO.,LTD.
		HCFA Model		WP20SLi
	1.2	Manufacturer's Type Designation		CBD20-AMA-SI
	1.4	Operator Type: hand, pedestrian, standing, seated, order-picker		Pedestrian
	1.5	Rated Capacity/rated load	Q (lbs/kg)	4000/2000
	1.6	Load Centre Distance	c (in/mm)	24/600
	1.8	Load Distance, centre of drive axle to fork	x (in/mm)	37.8/960
	1.9	Wheelbase	y (in/mm)	44 ³⁾ /1123 ³⁾
Weight	2.1	Service Weight (Including battery)	lbs/kg	330/150
		Battery Weight	lbs/kg	17/7.7
Tires & Chassis	3.1	Tires: solid rubber, superelastic, pneumatic, polyurethane		PU
	3.2	Tire Size, front		Φ210x70 / Φ8.3x2.8
	3.3	Tire Size, rear		Φ80x64 / Φ3x2.5
	3.5	Wheels, number front / rear (x = driven wheels)		1x/4
	3.7	Tread, rear	b _{r1} (in/mm)	15.75/400
Dimensions	4.4	Lift	h ₃ (in/mm)	4.7/120
	4.15	Fork Height, lowered	h ₁₃ (in/mm)	3.15/80
	4.19	Overall Length	l ₁ (in/mm)	61.5/1562
	4.21	Overall Width	b ₁ (in/mm)	22/560
	4.22	Fork Dimensions	s/e/l (in/mm)	2/6.3/45.3 / 50/160/1150
	4.25	Distance between Fork-Arms	b ₅ (in/mm)	22/26.8 / 560/680
	4.32	Ground Clearance, centre of wheelbase	m ₂ (in/mm)	1.2/30
	4.34.1	Aisle Width for Pallets 39" x 47" Crossways	A _{st} (in/mm)	69.4 ¹⁾³⁾ / 1763 ¹⁾³⁾
	4.34.2	Aisle Width for Pallets 31.5" x 47" Lengthways	A _{st} (in/mm)	71.4 ²⁾³⁾ / 1813 ²⁾³⁾
	4.35	Turning Radius	W _a (in/mm)	51 ³⁾ / 1296 ³⁾
Performance Data	5.1	Travel Speed, laden/unladen	mph / km/h	2.8/3 / 4.5/4.8
	5.2	Lift Speed, laden/unladen	ln/s / m/s	1/1.4 / 0.025/0.035
	5.3	Lowering Speed, laden/unladen	m/s / ln/s	2/1.6 / 0.05/0.040
	5.8	Max Gradeability, laden/unladen	%	6/15
Electric Motor	6.1	Drive Motor Rating at S2 60 min	HP	0.9
	6.2	Lift Motor Rating at S3 15%	HP	1.1
	6.4	Battery Voltage, rated capacity	V/Ah	24/30
	8.1	Type of Drive Control		PMSM

Notes: 1). VDI 2198: +3.6in/345mm
 2). VDI 2198: +7.6in/192mm
 3). When fork is lowered,+3in/76mm

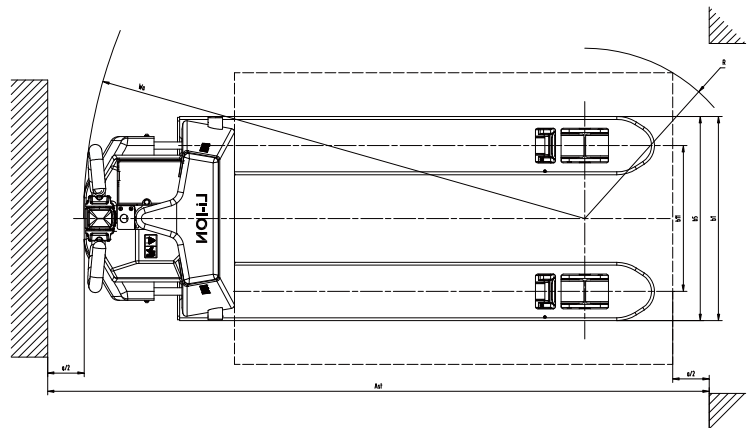
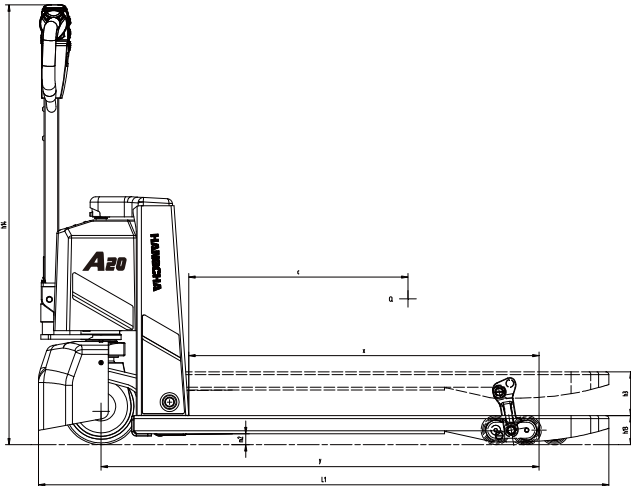





HANGCHA FORKLIFT CANADA INC.

Company address:

6-980 Rue Valois, Vaudreuil-Dorion,
QC, J7V 8P2, Canada

Toll Free: 877-319-HCFC (4232)

Landline: 450-319-HCFC

info@hcforkliftcanada.com

www.hcforkliftcanada.com



ISO14001:2015



ISO9001:2015



Follow us on
Facebook



Follow us on
YouTube



Follow us on
WeChat



Download "Hangcha
Forklift" App

HANGCHA GROUP CO., LTD. reserves the right to make any changes without notice concerning colors, equipment, or specifications detailed in this brochure, or to discontinue individual models. The colors of trucks, delivered may differ slightly from those in brochures.